

FAULKNER COUNTY  
**JIM B. BAKER**  
COUNTY JUDGE  
801 LOCUST STREET • CONWAY, AR 72034

FILED

DEC 04 2019

MARGARET DARTER  
FAULKNER COUNTY CLERK  
BY R. Walls DC

IN THE COUNTY COURT OF FAULKNER COUNTY, ARKANSAS

COURT ORDER 19-167

**IN THE MATTER OF  
ACCEPTING A BID FOR  
THE PURCHASE OF A  
NEW OFFSET VIBRATORY ROLLER ATTACHMENT**

Having opened and reviewed the submitted bid for the proposed New Offset Vibratory Roller Attachment for the Faulkner County Road Department, at 8:30 a.m. on December 4, 2019, the Faulkner County Court, by and through the County Judge, finds and orders as follows:

That G.W. Van Keppel Company shall be awarded the contract for the purchase of a new offset vibratory roller attachment, with the total bid price including taxes of \$60,455.00, pursuant to its bid, as a result of submitting the lowest responsible bid and meeting all other qualifications.

**IT IS SO ORDERED**



**Jim B. Baker**  
Faulkner County Judge  
December 4, 2019

To place an ad call **501.327.6621** or **800.678.4523**

# CLASSES FILED

Fax **501.327.6787** or Email [classifieds@thecabin.net](mailto:classifieds@thecabin.net)

**ANNOUNCEMENTS**

**SPECIAL NOTICE**

**FREE: INFORMATIONAL** booklet on protecting the rights of nursing home residents. (501) 607-8976. [www.aanhr.org](http://www.aanhr.org)

**TO THE** lady that bought the rainbow vacuum last Thursday, the shampooer was left behind. Please call to make arrangements for pick up. 501-470-5507.

**HAPPY ADS**

**MAY THE** sacred heart of Jesus be adored, glorified, loved and preserved throughout the world now and forever. Sacred heart of Jesus, pray for us. St. Jude, worker of miracles, pray for us. St. Jude, help of the hopeless, pray for us. Thank you, St. Jude, for granting my petition. Say this prayer 9 times a day.

**MERCHANDISE**

**HOUSEHOLD GOODS**

**WHITE BATH** bench. Good condition. \$35. Call 501-470-5507.

**FURNITURE**

**2 CHERRY** wood book shelves. Good condition. \$100 each. Call 501-470-5507.

**BRAND NEW** futon, beige/grey, folds out into bed. \$100 501-470-5507

**FREE!! NICE** set of living room furniture. Love red/black shop vac, man's. Brown suede. Great condition. Must pick up! 501-514-7607.

**LOVESEAT, SITS** two, beige in color, large cushions \$75 OBO 501-470-5507

**MAPLE ROCKER** with green cushions \$40 501-470-5507

**WANTED TO RENT/BUY**

**WANTED TO RENT/BUY**

**WANTED** to buy or free: Working or non-working lawnmowers. 501-327-4234 or 501-514-3659

**WANTED: WINCHESTER** 32-40 or Winchester 32WS rifles. Please call 501-548-7617. (Conway)

**WE BUY JUNK CARS,** trucks, farm machinery, scrap metal & more! NO TITLE NEEDED! No charge for pickup. 501-679-1611

**MISC. ITEMS FOR SALE**

**BLACK & DECKER** red/black shop vac, used once. \$45 501-470-5507

**ELECTRIC PORTABLE** floor bike exerciser, white in color, had hand attachments. \$50. 501-470-5507

**ELECTRIC SCOOTER,** \$200 obo. Been in storage, needs new battery. Call 501-733-1032

**ENTERTAINMENT GEN-**

**MISC. ITEMS FOR SALE**

**TABLE W/ 4** chairs, cushions need replacing. \$75 501-470-5507

**REAL ESTATE FOR RENT**

**285 GREAT Falls,** 3 bed 2 bath. \$800/Mo. \$500/Dep. NO PETS. Call Frieda 501-472-4130.

**HOMES FOR RENT**

**245 SOUTH Mitchell,** 3 bedroom, 1 bath. \$700 per month, \$500 deposit. 501-730-0184

**MOBILE HOMES FOR**

**3-BED,** 1-ba. 14x64 mobile home; \$500 deposit; \$550 rent. Central H/A. Appliances included. All elect., with water, sew-

**HOMES FOR SALE**

**HOUSE FOR** sale by owner: 2112 Tyler Street, 1148 sq ft. Completely remolded with new roof, siding windows, floors, inline water heater, stove & dishwasher, new cabinets, granite tops, new doors, sheet rock, paint and more. All walls interior/exterior insulated. \$116,500. Call 501-428-7909.

**UNFURNISHED APARTMENTS**

**TRINITY APARTMENTS**  
**2080 Broadview, Conway, AR**

Now taking applications!!  
40 Energy Saving Units  
Low utilities - central heat & air  
1 and 2 bedroom units  
V/TDD# (501)764-1179  
Financed by USDA- Rural Development  
Managed by Sunbelt Development Corp.  
This institution is an equal opportunity provider and employer.



**COMMERCIAL REAL ESTATE FOR RENT**

**OFFICE SPACES FOR LEASE**

**LEGALS**

**NOTICE TO BIDDERS**

Faulkner County will be accepting sealed bids on a New Offset Vibratory Roller Attachment. Bid specifications and Submittal Forms may be obtained from the Faulkner County Judge's Office. Bids will be accepted until 8:30 am on December 4, 2019 at which time they will be opened at the Faulkner County Judge's Office, located at 801 Locust Street Conway AR, 72034. Faulkner County reserves the right to accept or reject any or all bids placed and waive formalities. Bids should be submitted in total including taxes, for the price to be paid by Faulkner County.

FOB 65 Acklin Gap Road Conway Arkansas 72032. Direct questions and requests for clarifications related to this RFP to Mark Ledbetter at 501-450-4930.

Bids may be mailed to:  
Faulkner County Judge's Office  
Attn: New Offset Vibratory Roller Attachment  
801 Locust Street  
Conway AR, 72034

**LEGALS**

**NOTICE**

In accordance with Act 576 of 1987 of the Acts of Arkansas, Mark's Mini Storage intends to sell by a public sale, the contents of the following leased units:

**BRENDA BLOCK UNIT G02**  
**TORREY BRADLEY UNIT D33**

Faulkner County, Arkansas

New Offset Vibratory Roller Attachment

**BID SHEET**

**FILED**

DEC 04 2019

MARGARET DARTER  
FAULKNER COUNTY CLERK

BY R. Wells DC

Total Bid Price including taxes: \$60,455.00

Delivery Date: 3 Weeks After Written Award Letter

Company Name: G. W. Van Keppel Company

Company Representative (Print name): Michael Burns

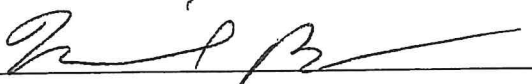
Company Representative (Signed Name): 

Date: 12-02-2019

BID INFORMATION AND BID SPECIFICATIONS

FOR

CONTRACTOR BIDDING PROJECT

THIS BID PACKET CONTAINS INFORMATION  
CONCERNING PROJECT FOR  
FAULKNER COUNTY, ARKANSAS  
COUNTY JUDGE JIM BAKER

New Offset Vibratory Roller Attachment

November 15, 2019

Faulkner County, Arkansas

New Offset Vibratory Roller Attachment

Date: November 15, 2019

Reference: New Offset Vibratory Roller Attachment

Bid is to be addressed to:

Faulkner County Judge's Office  
Attn: New Offset Vibratory Roller Attachment  
801 Locust Street  
Conway AR, 72034

**BIDS ARE DUE ON Wednesday, December 4, 2019 by 8:30 a.m.**

Bids may be mailed or hand delivered to Judge Jim Baker, County Judge, Faulkner County, Arkansas. All bids must be turned in prior to the 8:30 AM deadline.

\*\*\*\*\*Faxed, Phone, or e-mail bids will not be accepted.

\*\*\*\*\*All bids must be in a sealed envelope and marked Attn: New Offset Vibratory Roller Attachment

**FCRD**

**Offset Vibratory Roller Attachment**

**Specifications**

**And**

**Requirements**

**DRUM WIDTH: 36 inches**

**DRUM WEIGHT: 646lbs**

**ARM WEIGHT: 950lbs**

**MINIMUM CENTRIFICAL FORCE: 1513LBF**

**MINIMUM TOTAL APPLIED FORCE: 3110LBF**

**VPM: 2500-3500**

**AMPLITUDE: 0.226**

**MUST BE COMPATILBLE WITH CATERPILLAR MODEL 279DAH  
COMPACT TRACK LOADER OWNED BY FAULKNER COUNTY**

**FOB: 65 Acklin Gap Road**

**Conway AR, 72032**

# ROAD WIDENER OFFSET VIBE ROLLER

*Compacts All Aggregates  
Connects to Any Machine  
Patented Technology*

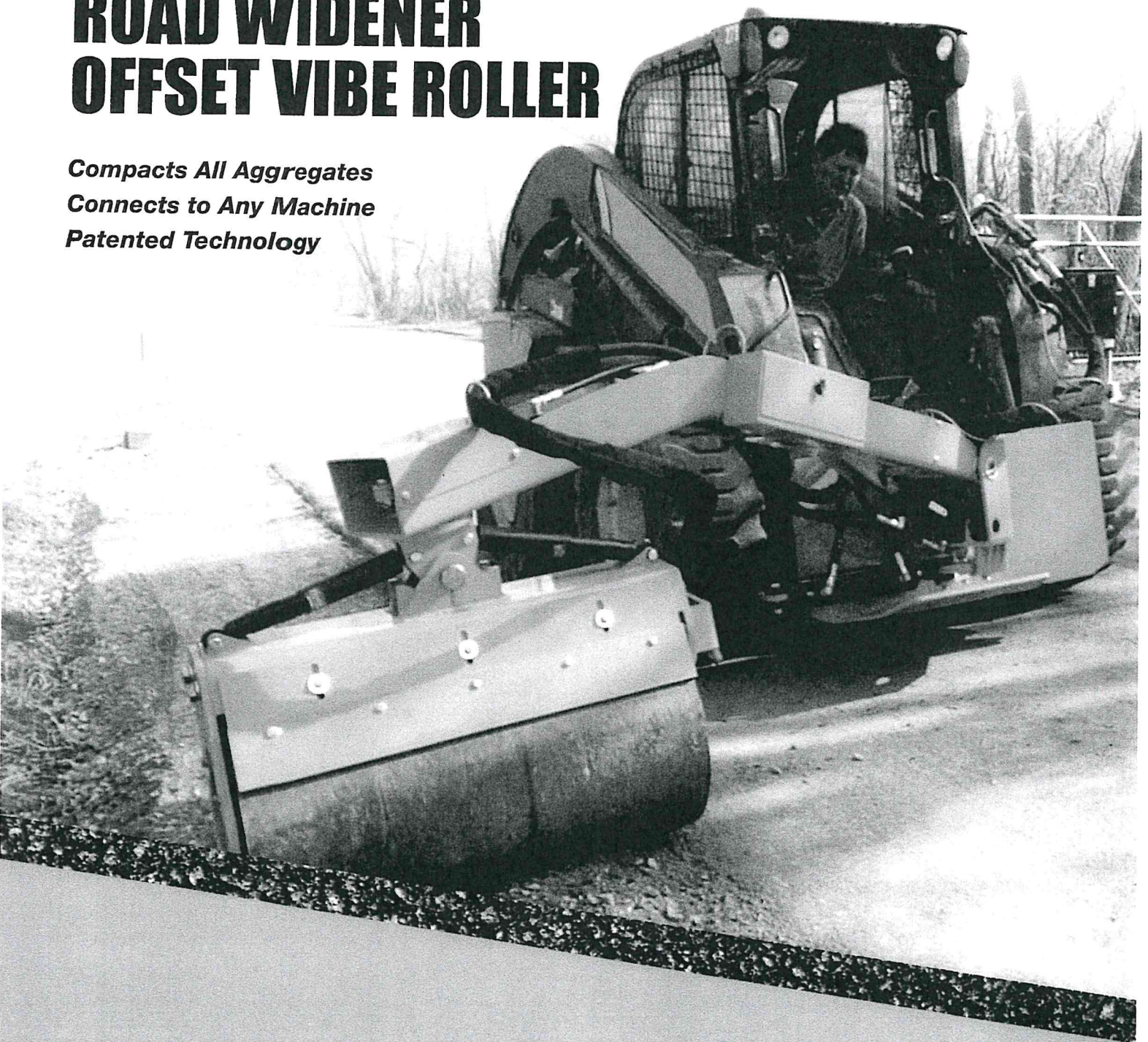

## ROADWIDENER®

1-844-494-3363 | [Sales@RoadWidenerLLC.com](mailto:Sales@RoadWidenerLLC.com)

[www.RoadWidenerLLC.com](http://www.RoadWidenerLLC.com)

# OFFSET VIBE ROLLER - PRODUCT SPECIFICATIONS

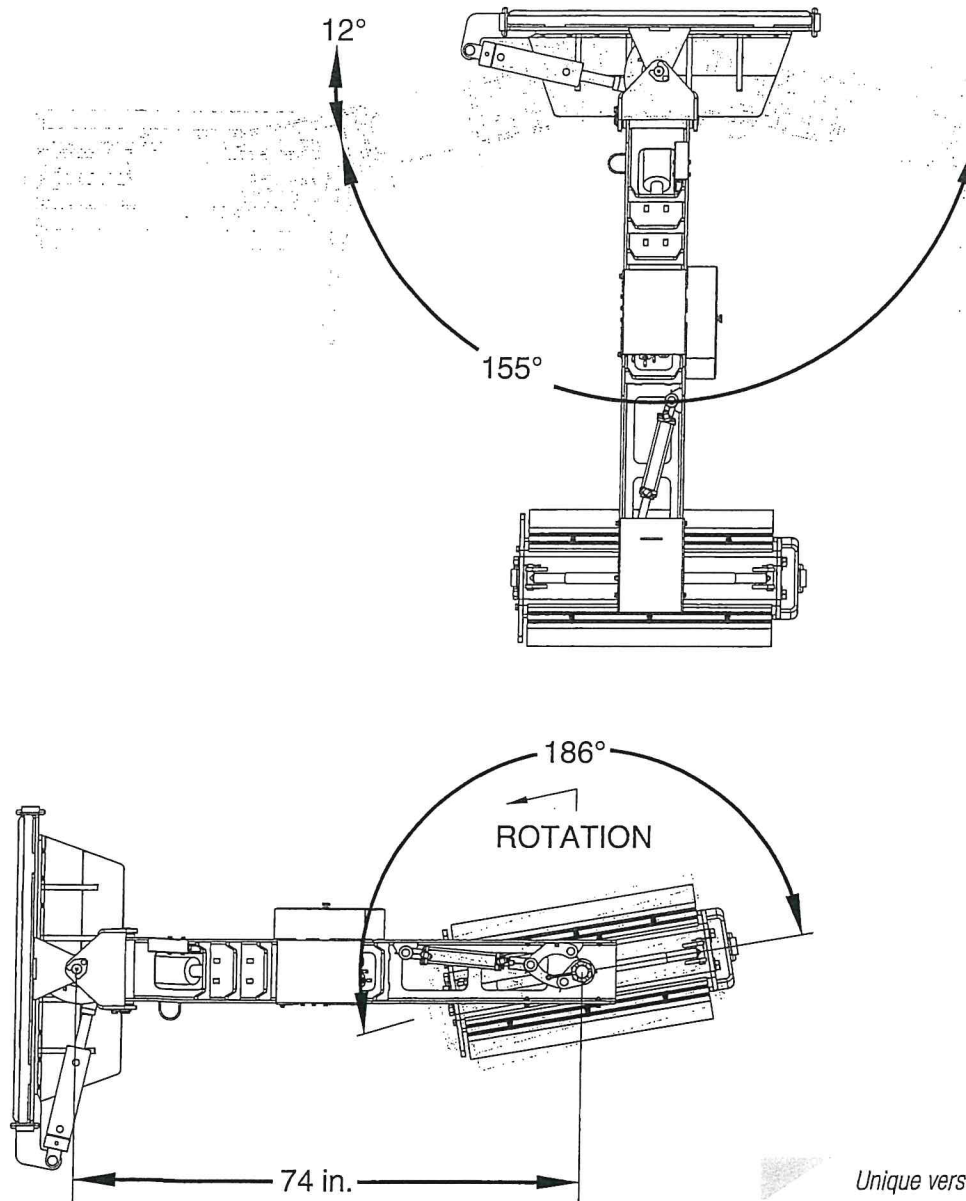

*Unique versatility creates unmatched safety.*

ARM WEIGHT (KG)	ARM WEIGHT (LB)	DRUM WIDTH (CM)	DRUM WIDTH (FT)	DRUM MASSV (KG)	DRUM MASSV (LB)	AMPLITUDE (MM)	AMPLITUDE (INCHES)	VPM
353	779	61.0	2'	283	625	0.47	0.02	500-2500
353	779	91.4	3'	384	847	0.47	0.02	500-2500
353	779	121.9	4'	455	1003	0.58	0.02	500-2500





*Offset feature allows operator to stay on the road while rolling and compacting shoulders and ditches.*



*Safest rolling solution on the market!*

- Safest roller on the market – one-of-a kind attachment
- Attaches to any machine via SAE quick connector coupling
- Requires only standard flow hydraulics
- Remote control puts functions in the hands of the operator
- Vibratory feature creates optimal compaction
- Can roll stone, asphalt, RAP, dirt
- Multiple roller widths 2', 3', and 4'
- Can roll outside slope of shoulder, not just horizontal edges (up to 30-degree drum pivot)
- Can be dropped down into trenches – drum goes to 30 inches below mounting point

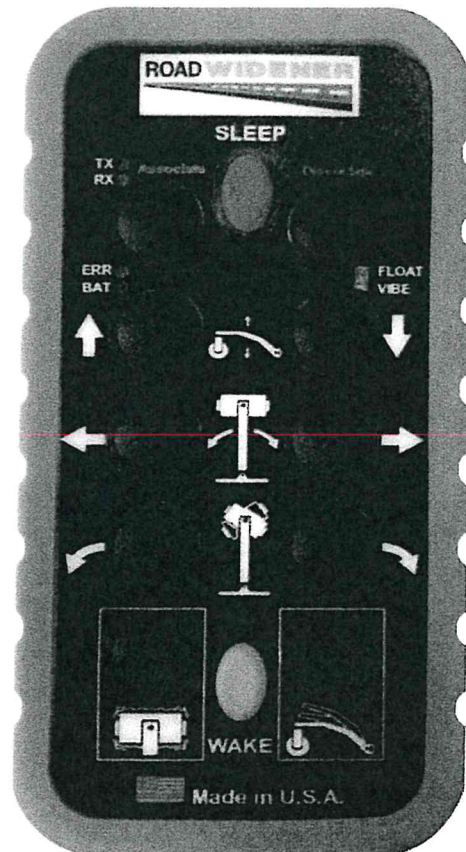

*Remote control*

# ROADWIDENER



Road Widener LLC

Dealer Inquiries: 888-871-3536

Sales 844-4WIDENER (844-494-3363)

[sales@roadwidenerllc.com](mailto:sales@roadwidenerllc.com)

[www.roadwidenerllc.com](http://www.roadwidenerllc.com)



Made in the USA

The G. W. Van Keppel Co.  
5427 Bethany Rd.  
N. Little Rock, AR 72117

*[Handwritten signature]*

RECEIVED  
DEC 02 2019

*[Handwritten]* 11:31 A.M.

Faulkner County Judges Office  
Attn: New Offset Vibratory Roller Attachment  
801 Locust Street  
Conway, AR. 72034

BID NO. New Offset Roller  
OPENED 12-04-19 8:30 AM

Faulkner County  
Invoice Affidavit

01\*00050 Log Cabin Democrat

Vendor Invoice	Date	Description	Amount
90835459	11/19/2019	Notice to Bidders- New Offset Vibratory Roller Attachment 11/19/19	62.60

Account	Amount	Account	Amount
2000.0200.3040	62.60		

Total for Vendor 01\*00050 Log Cabin Democrat 62.60

I certify this is a valid invoice against the county  
and request payment to:

Log Cabin Democrat  
1121 Front Street

Tax Information

Code:

Taxes Due?

Tax Rebate?

CONWAY

AR 72032

Number of attached pages: 1

By  
Date Presented

Sally Strip  
12-5-19

# thecabin.net

Log Cabin Democrat

STATE OF ARKANSAS  
 COUNTY OF FAULKNER

90117143  
**Faulkner County Judge**  
 801 Locust  
 Conway, AR 72034

FILED

DEC 06 2019

MARGARET DARTER  
 FAULKNER COUNTY CLERK  
 BY R. Walls DC

I, Eden Cameron, do hereby certify that I am the Authorized Agent of the Log Cabin Democrat, a daily newspaper published in the city of Conway, Arkansas, and having a bonafide circulation in Faulkner County, Arkansas, that said newspaper has been published at regular intervals continuously during a period of at least twelve (12) months prior to the date of publication of the annexed:

**Notice to bidders**

and is in all respects eligible and qualified to publish legal notices under the provisions of Act 152 of the 1937 Acts of the General Assembly of the State of Arkansas as amended by Act 263 of the 1937 Acts of the General Assembly of the State of Arkansas.

I further certify that said legal advertisement, a copy of which is hereby attached, was published in said newspaper on the following days, to wit:

Ad Number	Date Published
90835459	11/19/19

AFFIANT: Eden Cameron

Subscribed and sworn to, this 19 day of November, 2019.

Notary Public: E. Lu Walsh

My commission expires December 13, 2026

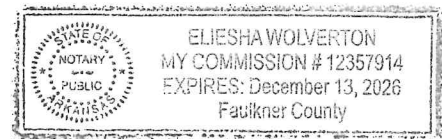

Cost for Printing: \$57.60  
 Cost of Affidavit: \$5.00  
 Total Cost: \$62.60

**LEGALS**

**NOTICE TO BIDDERS**

Faulkner County will be accepting sealed bids on a New Offset Vibratory Roller Attachment. Bid specifications and Submittal forms may be obtained from the Faulkner County Judge's Office. Bids will be accepted until 8:30 am on December 4, 2019 at which time they will be opened at the Faulkner County Judge's Office, located at 801 Locust Street Conway AR, 72034. Faulkner County reserves the right to accept or reject any or all bids placed and waive formalities.

Bids should be submitted in total including taxes, for the price to be paid by Faulkner County.  
 FOB 65 Acklin Gap Road Conway Arkansas 72032.  
 Direct questions and requests for clarifications related to this RFP to Mark Ledbetter at 501-450-4930.

Bids may be mailed to:  
**Faulkner County Judge's Office**  
**Attn: New Offset Vibratory Roller Attachment**  
**801 Locust Street**  
**Conway AR, 72034**